

601clikcase

light duty



> TECHNICAL SPECIFICATIONS

material :	polypropylene
unit weight (no foam) :	0.6 lbs (0.27 kg)
qty per pack :	30
pack weight (no foam) :	18 lbs (8.16 kg)
airline carry-on :	yes
watertight :	no
warranty :	manufacturing defects
wheels :	no

> CASE DIMENSIONS

interior :	4.62" x 9" x 2.7" (117.3 x 228.6 x 68.6 mm)
exterior :	5" x 11.77" x 2.95" (127 x 299 x 75 mm)

>> COLORS

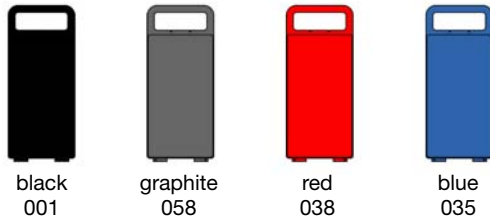

>> CASE DIMENSIONS

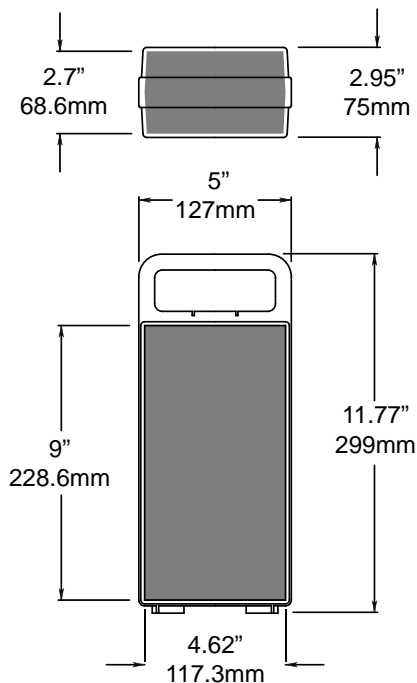

>> STANDARD FEATURES



> integrated handle



> integrated latches



> strong metal core hinges

>> AVAILABLE OPTIONS

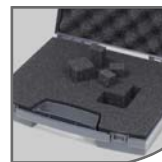

> cubed foam

Made of 1.8 lbs polyurethane foam, these three-piece sets of customizable foam inserts include a pre-scored cubed layer.



> custom die cut foam

Plasticase can also develop customized die-cut foam inserts as well as offer ready-made customizable inserts for some of our products



> silk screen printing

Our printing department can personalize your cases to bear your image and message.