

## 608clikcase

light duty



### > TECHNICAL SPECIFICATIONS

material :	<b>polypropylene</b>
unit weight (no foam) :	<b>0.83 lbs (0.52 kg)</b>
qty per pack :	<b>20</b>
pack weight (no foam) :	<b>16.6 lbs (7.53 kg)</b>
airline carry-on :	<b>yes</b>
watertight :	<b>no</b>
warranty :	<b>manufacturing defects</b>
wheels :	<b>no</b>

### > CASE DIMENSIONS

interior :	<b>10.31" x 6.87" x 3.75"</b> <b>(261.8 x 174.5 x 95.3 mm)</b>
exterior :	<b>10.69" x 9.33" x 4"</b> <b>(271.5 x 226.9 x 101.6 mm)</b>

### >> COLORS



black  
001

graphite  
058

red  
038

blue  
035

### >> CASE DIMENSIONS

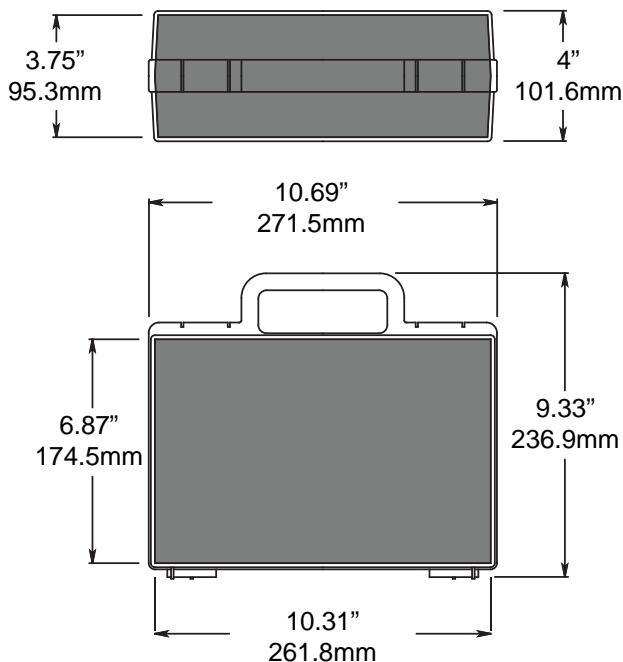

### >> STANDARD FEATURES



> integrated handle



> integrated latches



> strong metal core hinges

### >> AVAILABLE OPTIONS



> cubed foam

Made of 1.8 lbs polyurethane foam, these three-piece sets of customizable foam inserts include a pre-scored cubed layer.



> custom die cut foam

Plasticase can also develop customized die-cut foam inserts as well as offer ready-made customizable inserts for some of our products



> silk screen printing

Our printing department can personalize your cases to bear your image and message.