

610clikcase

light duty



> TECHNICAL SPECIFICATIONS

| | |
|-------------------------|------------------------------|
| material : | polypropylene |
| unit weight (no foam) : | 1.3 lbs (0.59 kg) |
| qty per pack : | 10 |
| pack weight (no foam) : | 13.0 lbs (5.9 kg) |
| airline carry-on : | yes |
| watertight : | no |
| warranty : | manufacturing defects |
| wheels : | no |

> CASE DIMENSIONS

| | |
|------------|--|
| interior : | 13.75" x 9.5" x 2.7" (349.2 x 241.3 x 68.6 mm) |
| exterior : | 14.13" x 11.95" x 2.95" (358.9 x 238.3 x 74.9 mm) |

>> COLORS

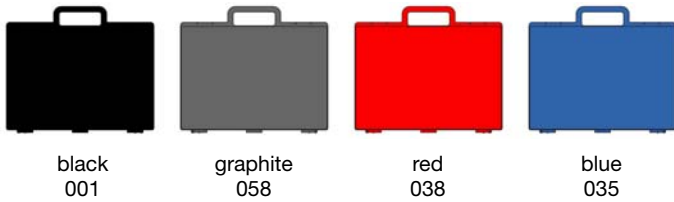

>> CASE DIMENSIONS

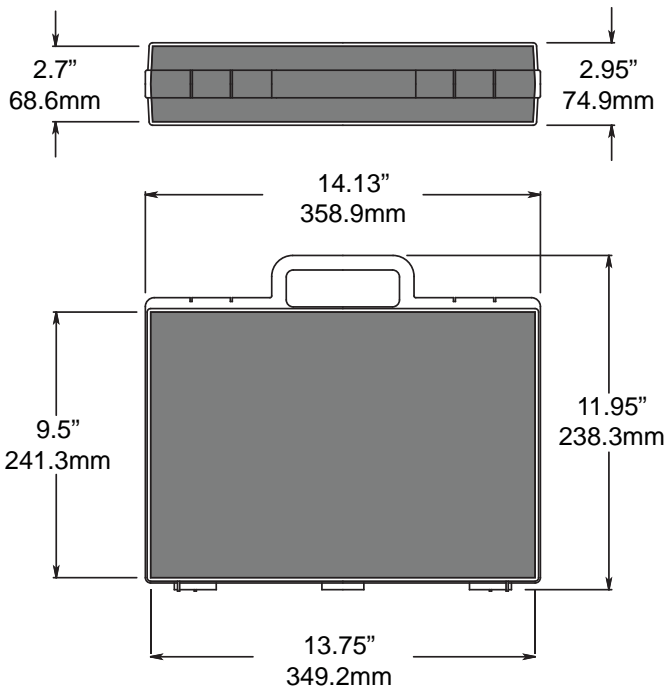

>> STANDARD FEATURES



> integrated handle



> integrated latches



> strong metal core hinges

>> AVAILABLE OPTIONS

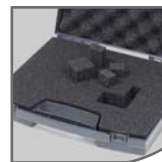

> cubed foam

Made of 1.8 lbs polyurethane foam, these three-piece sets of customizable foam inserts include a pre-scored cubed layer.



> custom die cut foam

Plasticase can also develop customized die-cut foam inserts as well as offer ready-made customizable inserts for some of our products



> silk screen printing

Our printing department can personalize your cases to bear your image and message.