

634maxcase

medium duty



> TECHNICAL SPECIFICATIONS

material :	polypropylene
unit weight (no foam) :	2.28 lbs (1.03 kg)
qty per pack :	8
pack weight (no foam) :	23 lbs (10.43 kg)
airline carry-on :	Yes
watertight :	no
warranty :	manufacturing defects
wheels :	no

> CASE DIMENSIONS

interior :	14.25" x 10.25" x 5.25" (363 x 262 x 133 mm)
exterior :	15.25" x 13.5" x 5.5" (388 x 343 x 140 mm)

>> COLORS



>> STANDARD FEATURES



> integrated handle



> nylon latches

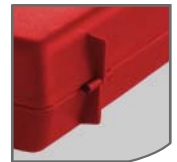

> strong metal core hinges

>> CASE DIMENSIONS

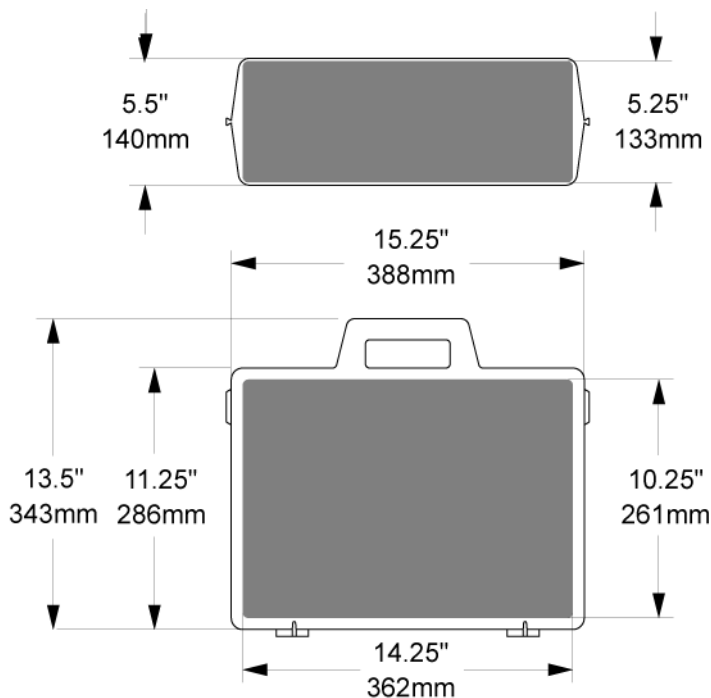

>> AVAILABLE OPTIONS

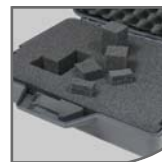

> pick and pluck foam

Made of 1.8 lbs polyurethane foam, these three-piece sets of customizable foam inserts include a pre-scored 'pick and pluck' layer.



> custom die cut foam

Plasticase can also develop customized die-cut foam inserts as well as offer ready-made customizable inserts for some of our products



> silk screen printing

Our printing department can personalize your cases to bear your image and message.