

## 640techcase

medium duty



### > TECHNICAL SPECIFICATIONS

material :	<b>polypropylene</b>
unit weight (no foam) :	<b>2.59 lbs (1.8 kg)</b>
qty per pack :	<b>8</b>
pack weight (no foam) :	<b>20.72 lbs (0.5 kg)</b>
airline carry-on :	<b>yes</b>
watertight :	<b>no</b>
warranty :	<b>manufacturing defects</b>
wheels :	<b>no</b>

### > CASE DIMENSIONS

interior :	<b>16.75" x 12" x 4.25"</b> <b>(425 x 305 x 108 mm)</b>
exterior :	<b>17.75" x 15.5" x 4.5"</b> <b>(451 x 394 x 114 mm)</b>

### >> COLORS



black 001    blue 035    mercury 050    graphite 058    navy 065

### >> CASE DIMENSIONS

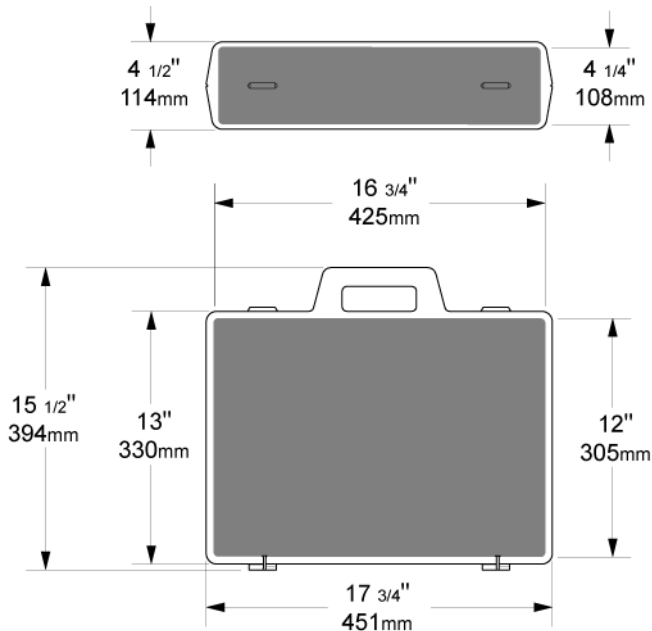

### >> STANDARD FEATURES



> integrated handle



> nylon latches

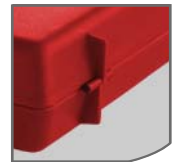

> strong metal core hinges

### >> AVAILABLE OPTIONS

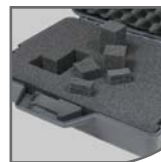

#### > pick and pluck foam

Made of 1.8 lbs polyurethane foam, these three-piece sets of customizable foam inserts include a pre-scored 'pick and pluck' layer.



#### > custom die cut foam

Plasticase can also develop customized die-cut foam inserts as well as offer ready-made customizable inserts for some of our products



#### > silk screen printing

Our printing department can personalize your cases to bear your image and message.